

Automatic Transfer Switch Option Manual Return to Normal

Introduction

The standard override TDR pushbutton, (ORPB), will override the time delay imposed by the TDR timer described below.

TDR Time Delay Return. This timer is adjustable from 0.0 to 60.0 minutes and is **FACTORY SET AT 12 MINUTES**. It is initiated upon the restoration of normal power and will inhibit the switch from retransferring to the normal source until it has timed out. If at any time during the timing cycle normal power is not maintained, this timer will be terminated and will be reinitiated when normal power returns.

The Manual Return to Normal (MRTN) option eliminates the "TDR" (Time Delay to Return) timer and a maintained switch replaces the momentary ORPB. In the standard operation of the automatic transfer switch (ATS) with a MRTN feature enabled, the ATS will never transfer to the normal power source unless this input is activated.

Product Features

- Manual Return to Normal (Manual Operation Required)

Standard MRTN Operation

Microprocessor Controls, MRTN

Entry into the ATS enclosure is required for this step. Be sure all the appropriate PPE required is being used.

To return the ATS to the normal source, flip the MRTN switch. The transfer switch will instantly transfer the load to the normal source, if available, and shut down the engine.

Figure 1 shows how the MRTN switch is wired into the microprocessor control circuit. If a remote MRTN input is required, simply wire a parallel control switch across the MRTN input. A terminal block is available for field wiring upon request.

Electromechanical Controls, 15

Entry into the ATS enclosure is required for this step. Be sure all the appropriate PPE required is being used.

To return the ATS to the normal source, flip the MRTN toggle switch. The transfer switch will instantly transfer the load to the normal source, if available, and shut down the engine.

If a remote MRTN input is required, a terminal block wired in parallel to the MRTN is available for field wiring upon request. This will allow a remote input to control the ATS.

See Electromechanical Controls Overview Datasheet for more information.

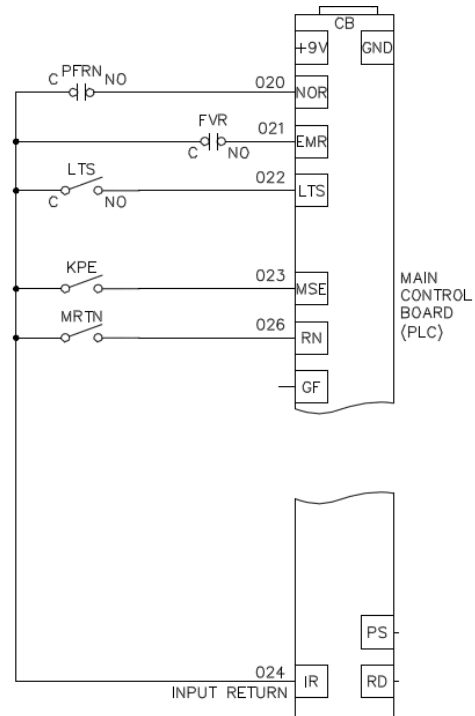

Figure 1

Order Guide

Part Number Examples:

1. ICFA32000BPSB/MRTN - Insulated Case ATS, 3 pole, 2000 Amp, 120/208Vac, **24Vdc Microprocessor Controls**, 65kAIC @ 480Vac, NEMA 1 Free Standing Enclosure with Option MRTN.
2. MCDA30400CESA/15 - Molded Case ATS, 3 pole, 400 Amp, 277/480Vac, **Electromechanical Controls**, 35kAIC @ 480Vac, NEMA 1 Wall Mount Enclosure with Option 15.