



Connect:

QCM

Quick Connect with Manual Transfer Switch

0–480VAC, 150A–4000A, up to 100kAIC
Specification Sheet & Selection Guide

Table of Contents



QCM Overview	
General Description.....	2
Technical Data	
Molded Case (150A - 1200A)	3
Insulated Case (1600A - 4000A)	4
QCM Selection Guide	
Characters & Designations	5
Model Code Configuration	6
Accessory Code Configuration	7
Weights & Dimensions	
Molded Case (150A - 1200A)	8
Insulated Case (1600A - 4000A)	9
Connection Information	
Lug Size & Quantity.....	10
Drawings	
Molded Case (150A - 400A)	12
Molded Case (800A - 1200A)	13
Insulated Case (1600A - 3200A)	14

QCM Overview

General Description



Lake Shore Electric's QCM (Quick Connect with Manual Transfer Switch) combines the safety and functionality of a Manual Transfer Switch with the convenience of a Quick Connection Cabinet, allowing for compliance with NEC 700.3(F).

NEC 700.3(F) 2017 States:

If the emergency system relies on a single alternate source of power, which will be disabled for maintenance or repair, the emergency system shall include permanent switching means to connect a portable or temporary alternate source of power, which shall be available for the duration of the maintenance or repair.

In short, the QCM is a practical and code-compliant solution for connection of a temporary alternate source to ensure a continuous means of backup power.

Standard Configuration Includes:

- Two Mechanically Interlocked UL 489 Switches
- Color-Coded Camlock Receptacles for Temporary Connections
- NEMA 3R Enclosure
- Grounded Dead Front Covers
- Auxiliary Contact & Indicating Lights for Switch Position (Green – Normal Source, Red – Alternate Source)
- Auxiliary Contact & Indicating Lights for Source Availability (White – Normal Source, White – Alternate Source)
- 2-Wire Start Binding Post
- NEMA 5-20R GFCI Receptacle¹

Optional accessories are also available. See the QCM Selection Guide on page 5 for additional details.

¹ Power by others

Technical Data

Molded Case (150A - 1200A)



Table 1: QCM Switching Device – Molded Case Technical Details, SER

kAIC @ 480V	Rated Current (A)	Service Entrance					
		Normal Source (Breaker)			Alternate Source (Switch)		
		2 Pole †	3 Pole	4 Pole	2 Pole †	3 Pole	4 Pole
35	150	PDG22G0150TFF	PDG23G0150TFF	PDG24G0150TFF	PDG22G0150KNSN	PDG23G0150KNSN	PDG24G0150KNSN
	400	PDG32G0400TFA	PDG33G0400TFA	PDG34G0400TFA	PDG32G0400KNSN	PDG33G0400KNSN	PDG34G0400KNSN
50	800	PDG52K0800E2R	PDG53K0800E2R	PDG54K0800E2	PDG52K0800KNSN	PDG53K0800KNSN	PDG54K0800KNSN
	1200	PDG53K1200E4R	PDG53K1200E4R	PDG54K1200E4R	PDG52K1200KNSN	PDG53K1200KNSN	PDG54K1200KNSN
65	150	PDG22M0150TFF	PDG23M0150TFF	PDG24M0150TFF	PDG22M0150KNSN	PDG23M0150KNSN	PDG24M0150KNSN
	400	PDG32M0400TFA	PDG33M0400TFA	PDG34M0400TFA	PDG32M0400KNSN	PDG33M0400KNSN	PDG34M0400KNSN
	800	PDG52M0800E2R	PDG53M0800E2R	PDG54M0800E2	PDG52M0800KNSN	PDG53M0800KNSN	PDG54M0800KNSN
	1200	PDG52M1200E4R	PDG53M1200E4R	PDG54MK1200E4R	PDG52M1200KNSN	PDG53M1200KNSN	PDG54M1200KNSN

Table 2: QCM Switching Device – Molded Case Technical Details, Non-SER

kAIC @ 480V	Rated Current (A)	Non-Service Entrance		
		Normal & Alternate Source (Switches)		
		2 Pole	3 Pole	4 Pole
35	150	PDG22G0150KNSN	PDG23G0150KNSN	PDG24G0150KNSN
	400	PDG32G0400KNSN	PDG33G0400KNSN	PDG34G0400KNSN
50	800	PDG52K0800KNSN	PDG53K0800KNSN	PDG54K0800KNSN
	1200	PDG52K1200KNSN	PDG53K1200KNSN	PDG54K1200KNSN
65	150	PDG22M0150KNSN	PDG23M0150KNSN	PDG24M0150KNSN
	400	PDG32M0400KNSN	PDG33M0400KNSN	PDG34M0400KNSN
	800	PDG52M0800KNSN	PDG53M0800KNSN	PDG54M0800KNSN
	1200	PDG52M1200KNSN	PDG53M1200KNSN	PDG54M1200KNSN

- Models stated above are Eaton Power Defense Molded Case Breakers and/or switches
- An electronic trip unit may be used in place of thermal-magnetic trip unit at LSE discretion
- † 3-pole variant with the center phase open may be used in place of a 2-pole at LSE discretion
- Ground Fault Protection is included on all Service Entrance options 1000A and greater with a system voltage of 480Y/277VAC
- Arcflash Reduction Maintenance System™ (ARMS™) is included on all breakers 1000A and greater
- A higher withstand rating and/or frame rating may be used in place of a lesser rating at LSE discretion
- Contact factory for technical information on switching devices or withstand ratings not listed in Table 1 or Table 2
- Data subject to change without notice

Technical Data

Insulated Case (1600A - 4000A)



Table 3: QCM Switching Device – Insulated Case Technical Details, SER

kAIC @ 480V	Rated Current (A)	Service Entrance Rated			
		Normal Source (Breaker)		Alternate Source (Switch)	
		3 Pole	4 Pole	3 Pole	4 Pole
65	1600	MPS6163VEA162	MPS6164VEA162	MPS6163VEANN	MPS6164VEANN
	2000	MPS6203VEA202	MPS6204VEA202	MPS6203VEANN	MPS6204VEANN
	3200	MPS6323VEA322	MPS6324VEA322	MPS6323VEANN	MPS6324VEANN
100	1600	MPSC163VEA162	MPSC164VEA162	MPSC163VEA162	MPSC164VEA162
	2000	MPSC203VEA202	MPSC204VEA202	MPSC203VEA202	MPSC204VEA202
	3200	MPSC323VEA322	MPSC324VEA322	MPSC323VEA322	MPSC324VEA322
	4000	MPSC4N3VEA402	MPSC4N4VEA402	MPSC4N3VEA	MPSC4N4VEA

Table 4: QCM Switching Device – Insulated Case Technical Details, Non-SER

kAIC @ 480V	Rated Current (A)	Non-Service Entrance	
		Normal & Alternate Source (Switches)	
		3 Pole	4 Pole
65	1600	MPS6163VEANNN	MPS6164VEANNN
	2000	MPS6203VEANNN	MPS6204VEANNN
	3200	MPS6323VEANNN	MPS6324VEANNN
100	1600	MPSC163VEA162	MPSC164VEA162
	2000	MPSC203VEA202	MPSC204VEA202
	3200	MPSC323VEA322	MPSC324VEA322
	4000	MPSC4N3VEANNN	MPSC4N4VEANNN

- Models stated above are Eaton® Magnum PXR® Low Voltage Power Circuit Breakers and/or switches
- Ground Fault Protection is included on all Service Entrance options with a system voltage of 480Y/277VAC
- Arcflash Reduction Maintenance System™ (ARMS™) is included on all breakers
- A higher withstand rating and/or frame rating may be used in place of a lesser rating at LSE discretion
- Contact factory for technical information on switching devices or withstand ratings not listed in Table 1 or Table 2
- Data subject to change without notice

QCM Selection Guide

Characters & Designations



The QCM product line has a structured, smart-style model code ordering system. The complete model code is composed of 18 customer-selected characters. Each character identifies a feature or function of the design. The first thirteen characters of the model code define the basic configuration. The five characters that follow identify the service entrance rating as well as accessories.

Sample Model Code:

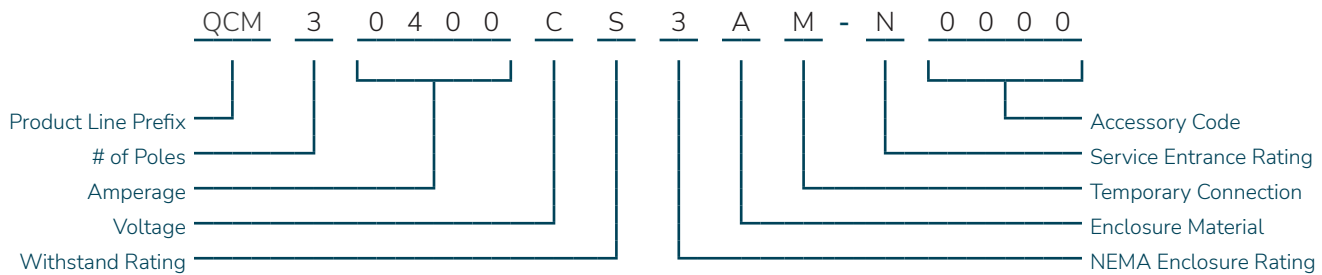

QCM Selection Guide

Model Code Configuration



Number of Poles

Following the QCM prefix of the model code is the number of poles. Available in configurations of 2-pole, 3-pole, and 4-pole, this selection is dependent on the system voltage.

Table 5: Number of Poles

Poles	Alpha Numeric
2	2
3	3
4	4

Amperage

With the exception of the 150A model, standard sizes of the QCM are available in 400A increments through 4000A. Contact the factory for alternate amperages.

Table 6: Amperage Codes

Amperage	Alpha Numeric
150A	0150
400A	0400
800A	0800
1200A	1200
1600A	1600
2000A	2000
3200A	3200
4000A	4000

Voltage Code

Identification of the voltage determines the color of camlock receptacles (per NEC standard), as well as control voltage circuits and service entrance requirements (when applicable).

Table 7: Voltage Codes

Voltage	Phase/Wire	Alpha Numeric
120/240VAC	1 Ph 3W	A
208Y/120VAC	3 Ph 4W	B
480Y/277VAC	3 Ph 4W	C
120/240VAC	3 Ph 4W	G
480VAC	3 Ph 3W	K

Withstand Rating

The below tables are based on UL 489 & 1066 Switching Device Ratings at 480VAC; Lower voltages offer higher kAIC ratings within the same alphanumeric code. Contact the factory for these ratings.

Table 8: Molded Case Withstand Code

Amperage	kAIC	Alpha Numeric
150A – 400A	35kAIC @ 480V	S
800A – 1200A	50kAIC @ 480V	S
150A – 1200A	65kAIC @480V	H

Table 9: Insulated Case Withstand Code

Amperage	kAIC	Alpha Numeric
1600A – 3200A	65kAIC @ 480V	S
4000A	100kAIC @ 480V	S
1600A – 3200A	100kAIC @480V	H

NEMA Enclosure Rating

The QCM is built with a minimum enclosure rating of NEMA 3R. Additional ratings are listed below.

Table 10: NEMA Code

Environmental Rating	Alpha Numeric
NEMA 3R	3

Enclosure Material

The standard enclosure material of the QCM is hot rolled steel with a textured ANSI 61 gray powder coat finish. Additional materials are listed below.

Table 11: Enclosure Code

Material	Alpha Numeric
Hot Rolled Steel – ANSI 61 Gray Powder Coat	A
Stainless Steel – 304 (#4 Brushed Finish)	C
Stainless Steel – 316 (#4 Brushed Finish)	D

Camlock Connection Style

Because the QCM can only be configured with male, 400A, single pole, UL 1691 listed receptacles, this character is fixed within the model code.

Table 12: Camlock Style Code

Connection Type	Ampacity	Alpha Numeric
Male	400A	M

QCM Selection Guide

Accessory Code Configuration



Service Entrance Rating Code

The service entrance option provides over-current protection along with neutral ground links. Service entrance rated QCM's that are 1200A and greater come standard with arc flash reduction features.

Table 13: Accessory Code 1

Rating	Alpha Numeric
Non-Service Entrance Rated	N
Service Entrance Rated	S

Accessory Code Position 1

The first position of the four-digit accessory code is reserved for future expansion to the QCM product line with 0 being the only available character at this time.

Table 14: Accessory Code 1

Description	Alpha Numeric
No Option (For Future Use)	0

Accessory Code Position 2

The second position of the four-digit accessory code offers a Phase Rotation Monitor.

- Phase Rotation Monitor uses a blue indicator light for confirmation of proper phasing when connecting a portable power source (Alternate Source).

Table 15: Accessory Code 2

Description	Alpha Numeric
No Option	0
Phase Rotation Monitor	2

Optional Leg Kit

A leg kit is available for QCM wall mount enclosures, which allows the unit to become free-standing. This kit is sold separately and can be purchased by using the part number below that corresponds to the enclosure material of the QCM.

Table 18: Leg Kit

Description	Part Number
Hot Rolled Steel – ANSI 61 Gray Powder Coat	QC-LK-474025-3A
Stainless Steel – 304 (#4 Brushed Finish)	QC-LK-474025-3C
Stainless Steel – 316 (#4 Brushed Finish)	QC-LK-474025-3D

Accessory Code Position 3

The third position of the four-digit accessory code provides the options for Space Heaters and Alternate Source Over-Current Protection.

- Space Heaters operate on 120VAC and may include a control power transformer when necessary. Over-Current protection and an adjustable thermostat are also provided.
- Alternate Source (Source 2) Over-Current Protection is available on Service Entrance Rated QCM's and will mirror the Over-Current protection utilized on the Normal Source (Source 1). Reference Table 1, Table 2, Table 3, & Table 4.

Table 16: Accessory Code 3

Description	Alpha Numeric
No Option	0
Space Heater	1
Alternate Source Over-Current Protection	2
Space Heater, Alternate Source Over-Current Protection	3

Accessory Code Position 4

The fourth position of the four-digit accessory code is reserved for future expansion to the QCM product line with 0 being the only available character at this time.

Table 17: Accessory Code 4

Description	Alpha Numeric
No Option	0

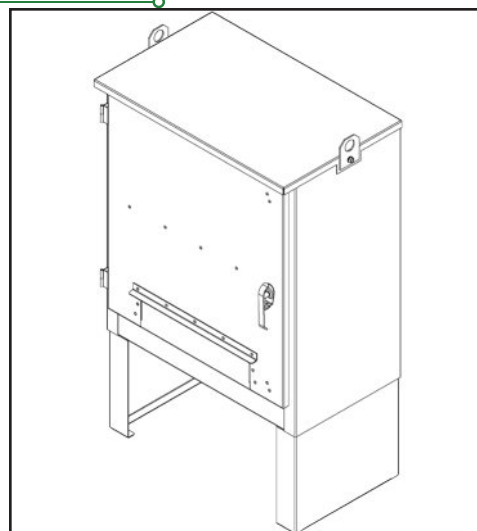

Weights & Dimensions

Molded Case (150A - 1200A)

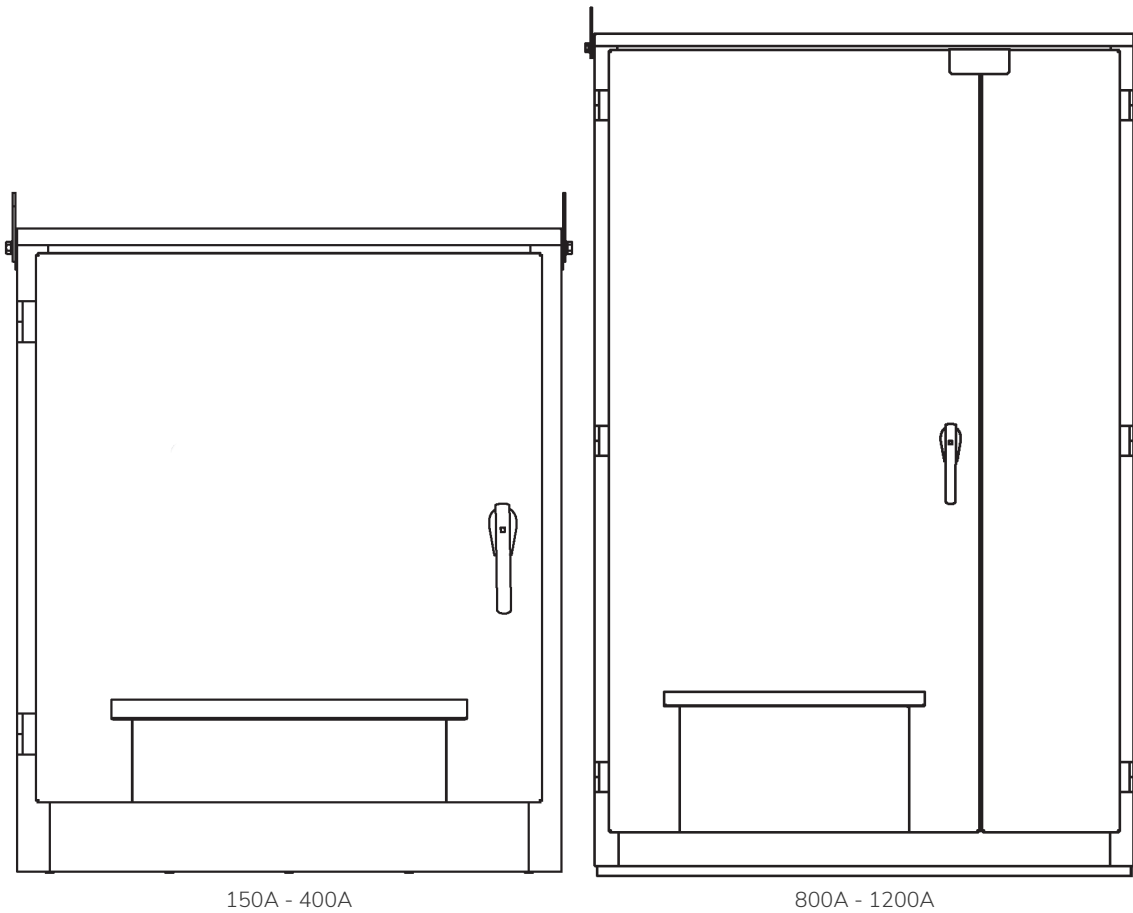

Table 19: Weights & Dimensions - Molded Case ¹

Ampacity	150 – 400 (Wall Mount Only)	800 – 1200 (Free Standing)
Height	47"	84"
Width	40"	54"
Depth	25"	25"
Approximate Weight	525 lbs	1300 lbs.
Drawing Number ¹	QCM0204-M001	QCM0812-M001

¹ Weights and dimensions are not for construction. Please refer to drawing for complete information

Weights & Dimensions

Insulated Case (1600A - 4000A)

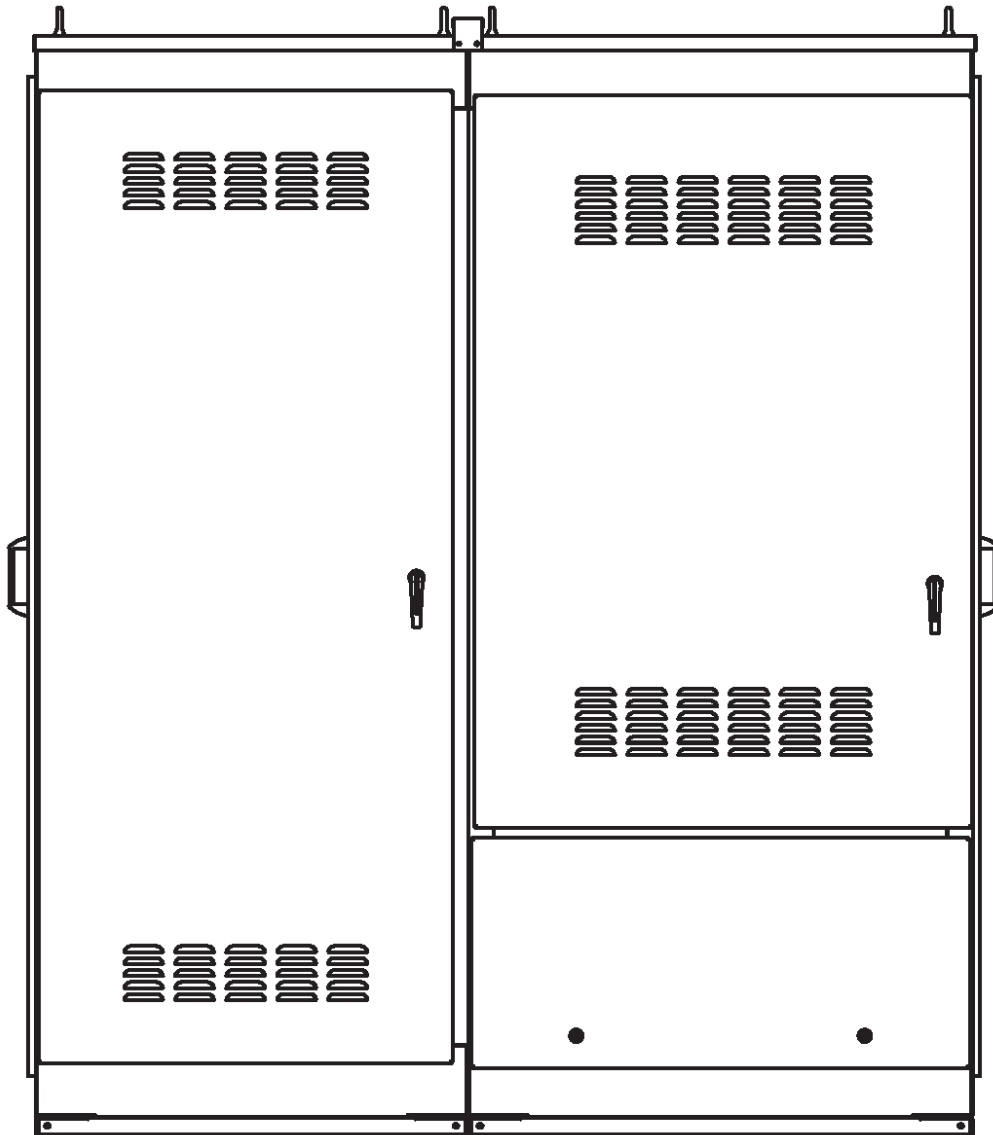

1600A - 3200A

Table 20: Weights & Dimensions - Insulated Case ¹

Ampacity	1600 - 3200	4000
Height	91"	Contact Factory
Width	72"	
Depth	36"	
Approximate Weight	2500 lbs	
Drawing Number ¹	QCM1632-M001	

¹ Weights and dimensions are not for construction. Please refer to drawing for complete information

Connection Information

Lug Size & Quantity



Table 21: Permanent Cable Termination Data

Ampacity	Location	Standard Lugs: Qty. & Range	Ground
150A	Source 1	(1) #6 – 350MCM	(1) #14 – 1/0
	Load	(1) #6 – 350MCM	
	Neutral	(1) #6 – 350MCM	
400A	Source 1	(2) #2 – 600MCM	(1) #14 – 1/0
	Load	(2) #2 – 600MCM	
	Neutral	(2) #2 – 600MCM	
800A	Source 1	(4) 300 – 750MCM	(1) #6 – 250MCM
	Load	(4) 300 – 750MCM	
	Neutral	(4) 300 – 750MCM	
1200A	Source 1	(4) 300 – 750MCM	(1) #6 – 250MCM
	Load	(4) 300 – 750MCM	
	Neutral	(4) 300 – 750MCM	
1600A	Source 1	(5) 300-750MCM	(4) #6 – 350MCM
	Load	(5) 300-750MCM	
	Neutral	(5) 300-750MCM	
2000A	Source 1	(6) 300-750MCM	(4) #6 – 350MCM
	Load	(6) 300-750MCM	
	Neutral	(6) 300-750MCM	
3200A	Source 1	(8) 300 – 750MCM	(4) #6 – 350MCM
	Load	(8) 300 – 750MCM	
	Neutral	(8) 300 – 750MCM	
4000A	Source 1	(12) 300 – 750MCM	(4) #6 – 350MCM
	Load	(12) 300 – 750MCM	
	Neutral	(12) 300 – 750MCM	

Contact Us

Lake Shore Electric, LLC.
5 Hemisphere Way
Bedford, OH 44146

Phone: 440.232.0200

E-Mail: Sales@lake-shore-electric.com

www.lseconnect.com/qcm

The information contained in this document is for general information purposes only. While Lake Shore Electric strives to keep the information up to date and correct, it makes no representations or warranties of any kind, express or implied, about the completeness, accuracy, reliability, suitability, or availability with respect to the information, products, services, or related graphics contained in the document for any purpose. Any reliance placed on such information is therefore strictly at your own risk. Lake Shore Electric reserves the right to discontinue any product or service at any time.



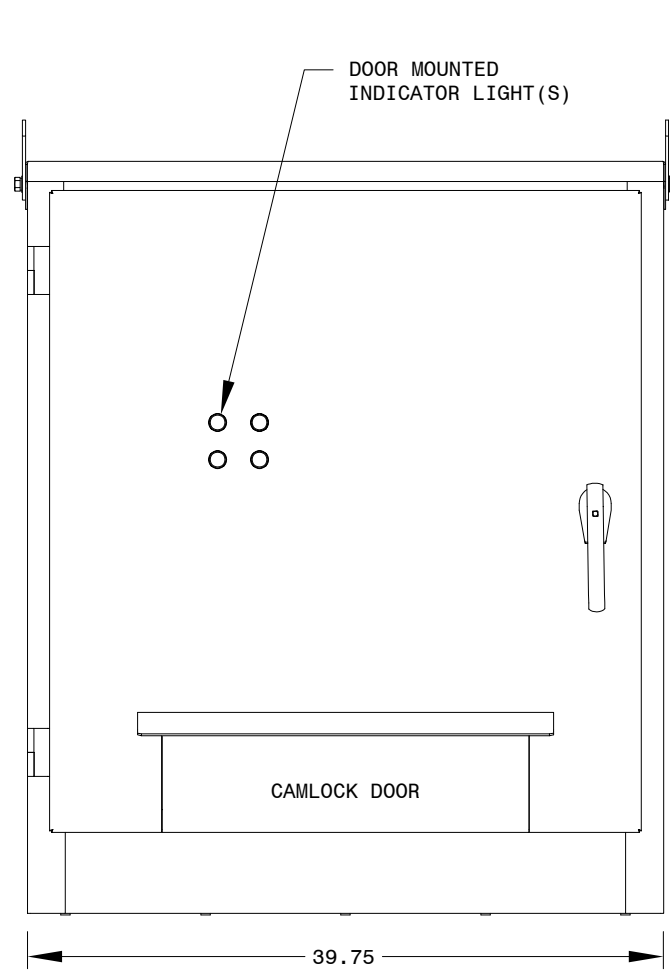

FRONT ELEVATION

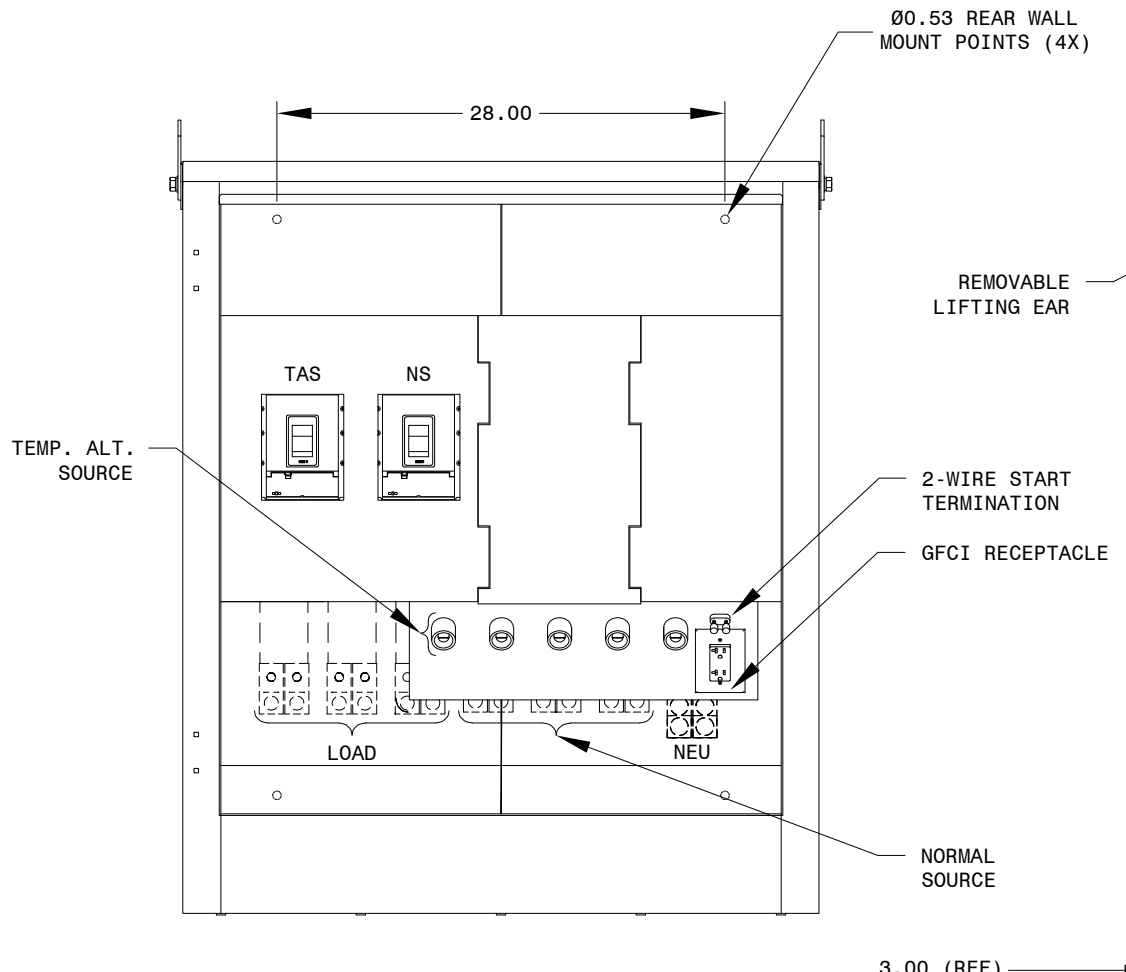

FRONT ELEVATION
DOOR REMOVED

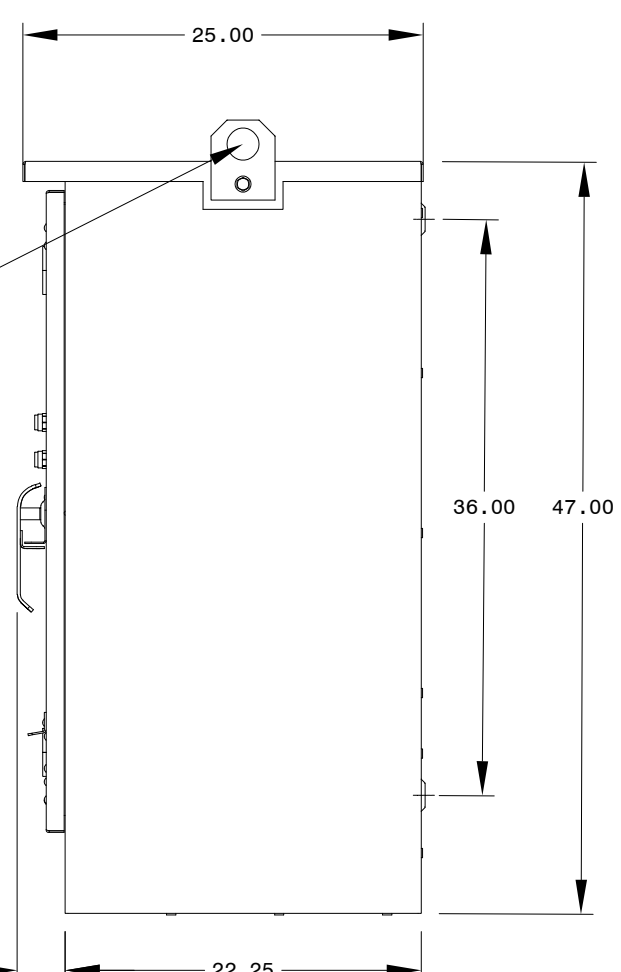

SIDE ELEVATION

- OUTLINE NOTES**
- 1) ENCLOSURE CONSTRUCTION: NEMA 3R
 - 2) WALL MOUNT
 - 3) CABLE ENTRY LOCATION: BOTTOM
 - 4) DOOR INFORMATION:
 MAIN DOOR: LEFT HINGED, PADLOCKABLE, WITH 3-POINT LATCHING
 CAMLOCK DOOR: TOP HINGED, INTERNAL LATCH
 - 5) DEADFRONTED
 - 6) CAMLOCKS
 A) COLOR AND ARRANGEMENT PER NATIONAL ELECTRIC CODE (NEC)
 B) MANUFACTURER & SERIES: CROUSE-HINDS "J" SERIES E1016, 400A RATING, ALL AMPACITIES, OR EQUIVALENT.
 - 7) ALL DIMENSIONS EXPRESSED IN INCHES
 - 8) ESTIMATED WEIGHT: 520LBS

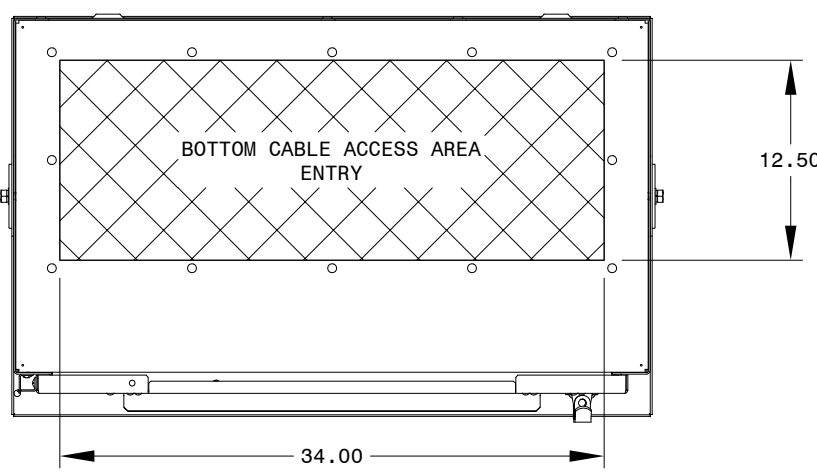
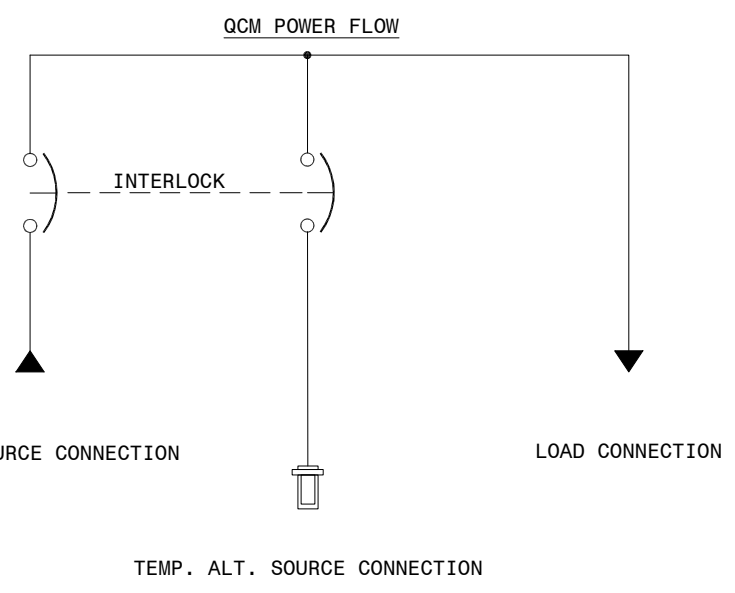

PLAN VIEW
FRONT

CABLE TERMINATIONS FOR LOAD AND NORMAL SOURCE			
AMPERAGE	TYPE	PHASE/NEU	GROUND
150A	NORMAL SOURCE	(1) #6-350MCM	(1) #14-1/0
	LOAD		
400A	NORMAL SOURCE	(2) #2-600MCM	
	LOAD		

REV	DESCRIPTION	BY	APV	DATE
-	ORIGINAL ISSUE	DGW	-	03/03/22
A	UPDATED DESIGN	DGW	-	10/25/22
B	UPDATED NOTES, FIXED RECP/2-WIRE CALLOUT	DGW	-	01/25/23
C	UPDATED LIGHT LOCATIONS	DGW	-	11/27/23
-	-	-	-	-
-	-	-	-	-
-	-	-	-	-

TITLE: QUICK CONNECT W/MANUAL TRANSFER SWITCH 150A-400A
 PLAN AND ELEVATION VIEWS

DWG NUMBER: QCM0204-M001

LAKE SHORE ELECTRIC LLC
 BEDFORD, OHIO U.S.A.

SCALE: NTS CREATED BY: DGW APV: - REVISION: C

THIS DOCUMENT IS THE PROPERTY OF Lake Shore Electric LLC. UNDER COPYRIGHT LAW, DISTRIBUTION AND REPRODUCTION OF THIS DOCUMENT, IN WHOLE OR IN PART, IS PROHIBITED WITHOUT PRIOR WRITTEN PERMISSION FROM Lake Shore Electric LLC.

PG 1 OF 1

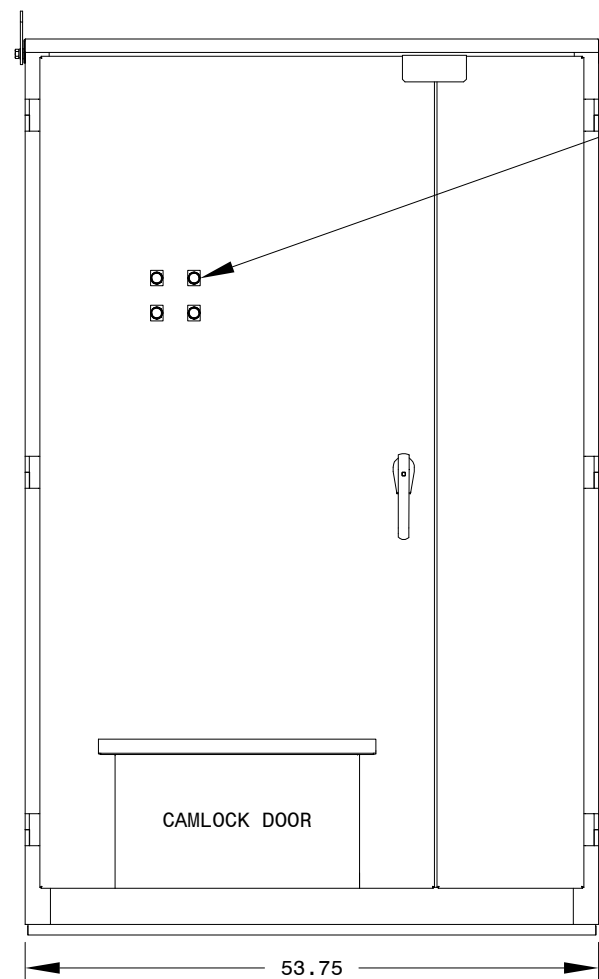

FRONT ELEVATION

DOOR MOUNTED INDICATOR LIGHT(S)



CAMLOCK DOOR

53.75

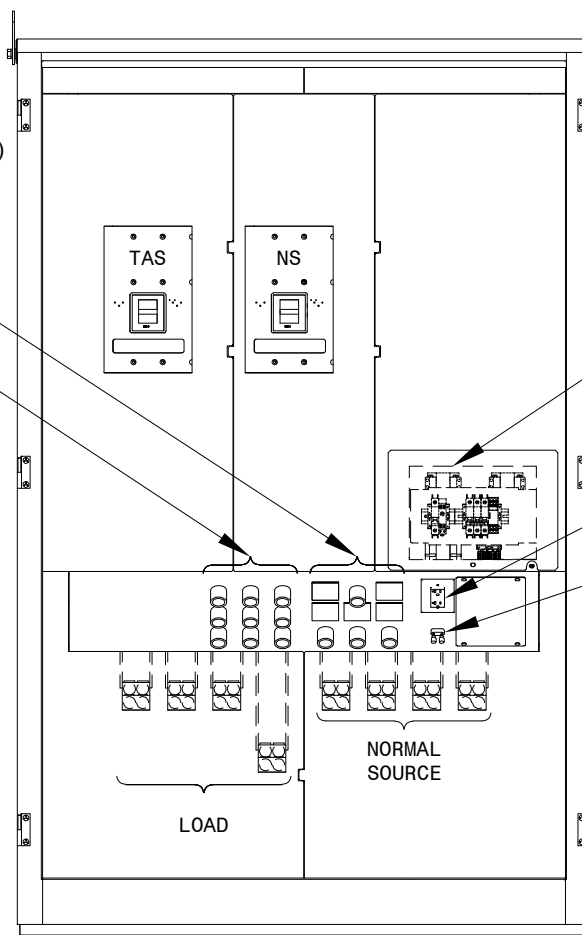

FRONT ELEVATION DOORS REMOVED

GND/NEU
TEMP. ALT. SOURCE

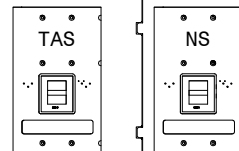

ELECTRICAL COMPONENTS

GFCI RECEPTACLE

2 WIRE START TERMINATION

NORMAL SOURCE

LOAD

REMOVABLE LIFTING EAR

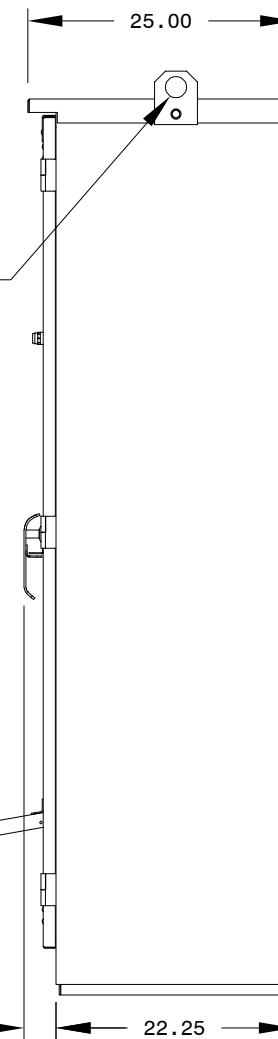

SIDE ELEVATION

OUTLINE NOTES

- 1) ENCLOSURE CONSTRUCTION: NEMA 3R
- 2) FREESTANDING
- 3) CABLE ENTRY LOCATION: BOTTOM
- 4) DOOR INFORMATION:
MAIN DOOR: LEFT HAND HINGE, PADLOCKABLE, WITH 3-POINT LATCHING
CAMLOCK DOOR: TOP HINGE, INTERNAL LATCH
- 5) DEADFRONTED
- 6) CAMLOCKS
A) COLOR AND ARRANGEMENT PER NATIONAL ELECTRIC CODE(NEC)
B) MANUFACTURER AND SERIES: CROUSE-HINDS "J" SERIES E1016, 400A RATING, ALL AMPACITIES, OR EQUIVALENT
- 7) ALL DIMENSIONS EXPRESSED IN INCHES
- 8) ESTIMATED WEIGHT: 1250LBS

84.00

3.00 (REF)

22.25

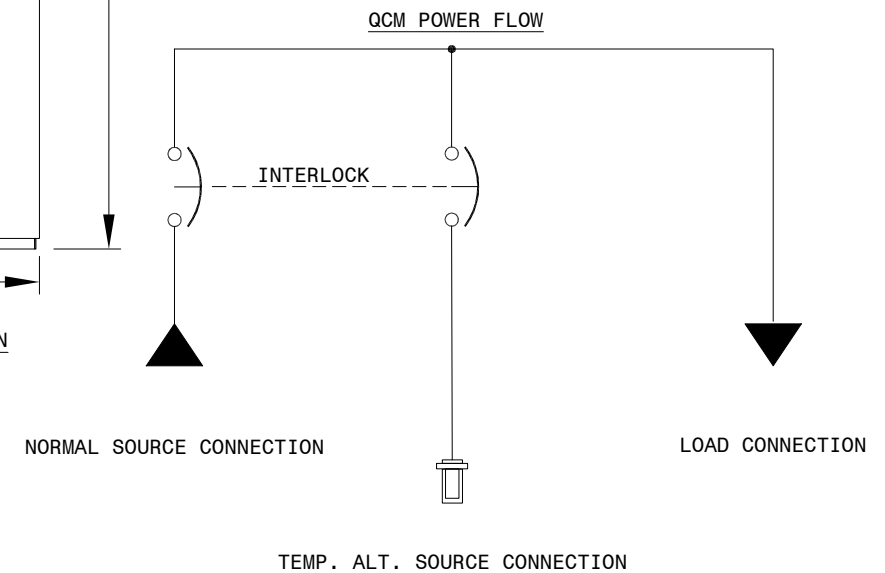

NORMAL SOURCE CONNECTION

LOAD CONNECTION

TEMP. ALT. SOURCE CONNECTION

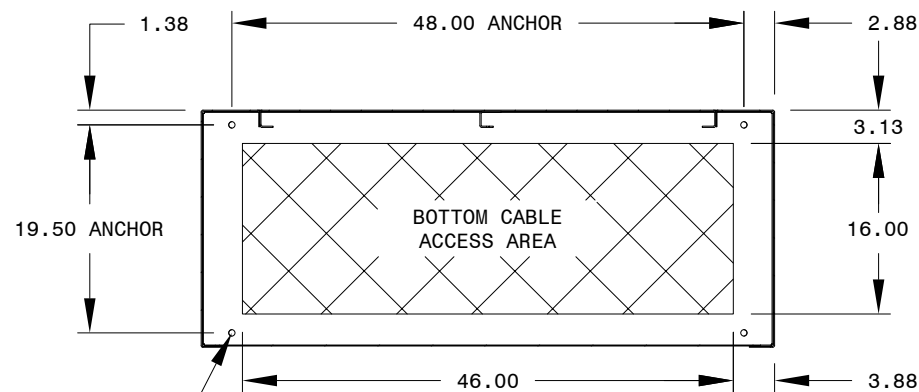

PLAN VIEW FRONT

Ø .656 HOLES (x4)

CABLE TERMINATIONS FOR LOAD AND NORMAL SOURCE

AMPERAGE	TYPE	PHASE/NEU	GROUND
800A-1200A	NORMAL SOURCE	(4) 300-750MCM	(1) #6-250MCM
	LOAD	(4) 300-750MCM	(1) #6-250MCM

TITLE: QUICK CONNECT W/MANUAL TRANSFER SWITCH 800A-1200A
PLAN AND ELEVATION VIEW

DWG NUMBER QCM0812-M001



SCALE: NTS CREATED BY: DGW APV: - REVISION: B

THIS DOCUMENT IS THE PROPERTY OF Lake Shore Electric LLC. UNDER COPYRIGHT LAW, DISTRIBUTION AND REPRODUCTION OF THIS DOCUMENT, IN WHOLE OR IN PART, IS PROHIBITED WITHOUT PRIOR WRITTEN PERMISSION FROM Lake Shore Electric LLC.

REV	DESCRIPTION	BY	APV	DATE
-	ORIGINAL ISSUE	DGW	-	03/03/22
A	NEW DESIGN (RENAMED)	DGW	-	10/28/22
B	UPDATED LIGHT LAYOUT	DGW	-	11/28/23
-	-	-	-	-
-	-	-	-	-
-	-	-	-	-
-	-	-	-	-

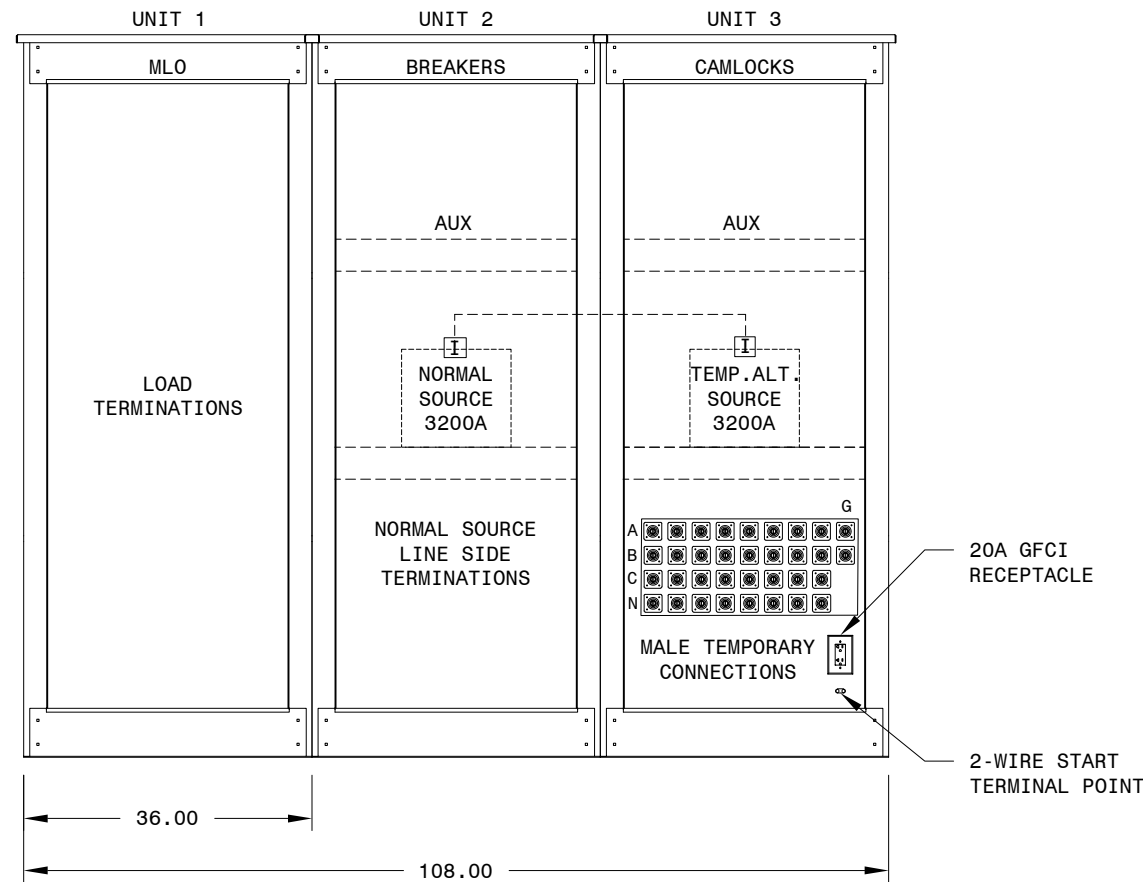

FRONT ELEVATION

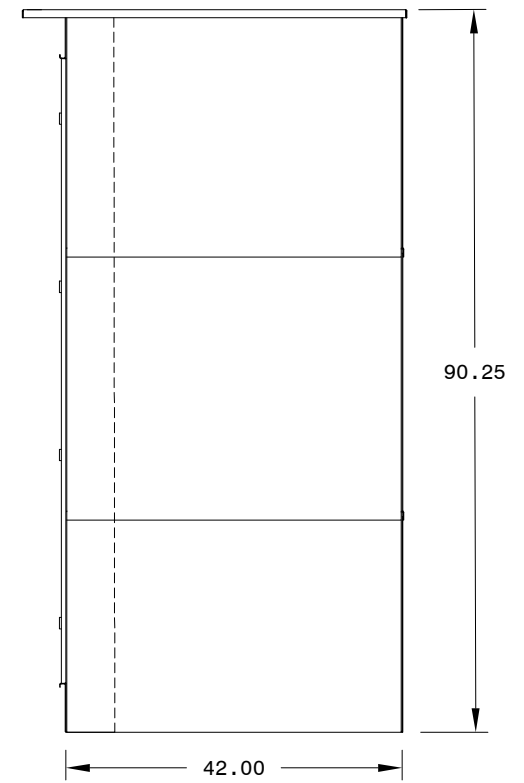

RIGHT ELEVATION

- OUTLINE NOTES
- 1) ENCLOSURE CONSTRUCTION: 14GA STEEL
 - 2) FINISH: POWDERCOAT, ANSI 61 (GREY), TEXTURED
 - 3) NEMA 3R FREESTANDING
 - 4) ESTIMATED WEIGHT: 3000 LBS
 - 5) CABLE ENTRY LOCATION: BOTTOM
 - 6) DOOR INFORMATION: LEFT HAND HINGE, GASKETED, THREE POINT LATCHING VIA SINGLE HANDLE
 - 7) ALL DIMENSIONS EXPRESSED IN INCHES
 - 8) DEADFRONTED
 - 9) QUICK CONNECTORS
 - A) COLOR AND ARRANGEMENT PER NATIONALE ELECTRIC CODE (NEC)
 - B) MANUFACTURER & SERIES: CROUSE-HINDS "J" SERIES E1016, 400A RATING, ALL AMPACITIES, OR EQUIVALENT.
 - 10) REMOVABLE REAR & BOTTOM COVERS
 - 11) FRONT & REAR ACCESS

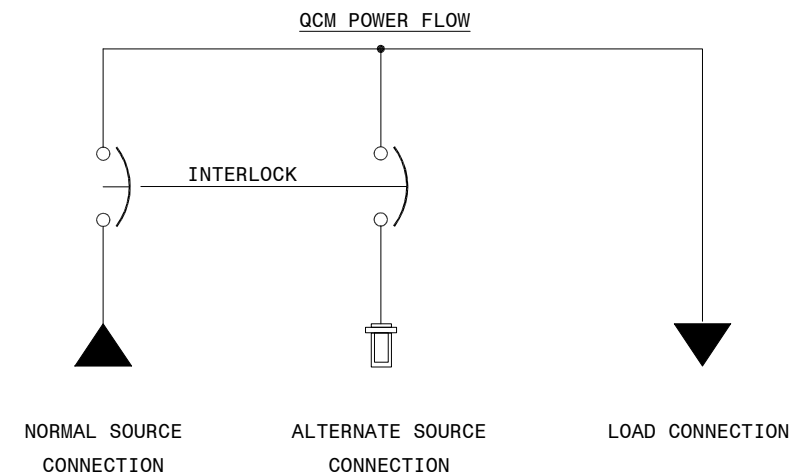

NORMAL SOURCE CONNECTION ALTERNATE SOURCE CONNECTION LOAD CONNECTION

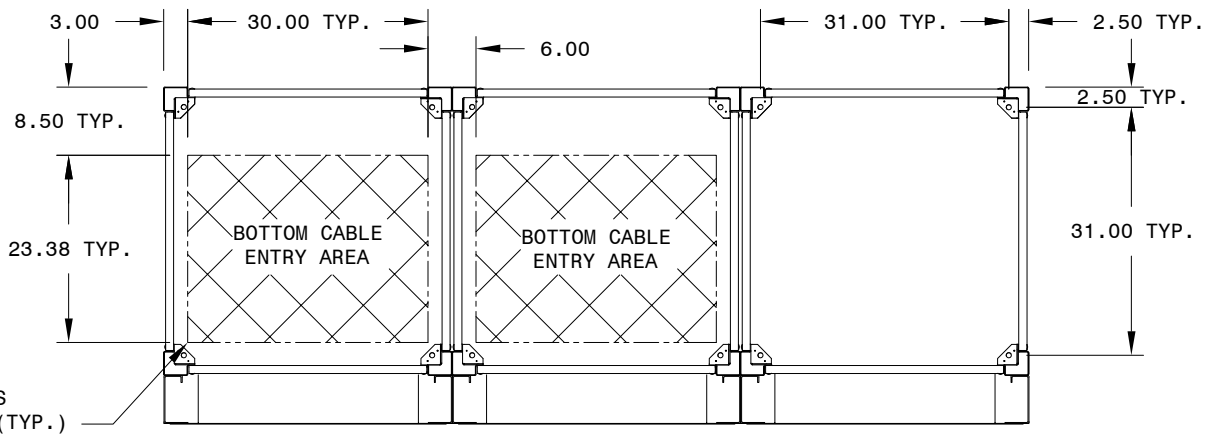

PLAN VIEW FRONT

PERMANENT CABLE TERMINATION DATA			
AMPACITY	TYPE	(CONDUCTOR QTY) RANGE	GROUND
1600A	SOURCE 1	(8) #2-600MCM	(4) #6-350MCM
	LOAD		
	NEUTRAL		
2000A	SOURCE 1	(8) 300-800MCM	
	LOAD		
	NEUTRAL		
3200A	SOURCE 1	(8) 300-800MCM	
	LOAD		
	NEUTRAL		

REV	DESCRIPTION	BY	APV	DATE
-	ORIGINAL ISSUE	DGW	-	03/03/22
A	UPDATED ENCLOSURE LAYOUT TO K SERIES STD	DGW	-	-
-	-	-	-	-
-	-	-	-	-
-	-	-	-	-
-	-	-	-	-
-	-	-	-	-

TITLE: QUICK CONNECT W/MANUAL TRANSFER SWITCH
QCM 1600A-3200A

DWG NUMBER: QCM3200-M001

LAKE SHORE ELECTRIC LLC
BEDFORD, OHIO U.S.A.

SCALE: NTS CREATED BY: DGW APV: - REVISION: A

THIS DOCUMENT IS THE PROPERTY OF Lake Shore Electric LLC. UNDER COPYRIGHT LAW, DISTRIBUTION AND REPRODUCTION OF THIS DOCUMENT, IN WHOLE OR IN PART, IS PROHIBITED WITHOUT PRIOR WRITTEN PERMISSION FROM Lake Shore Electric LLC.

PG 1 OF 1