

FLOOR PLAN
FRONT

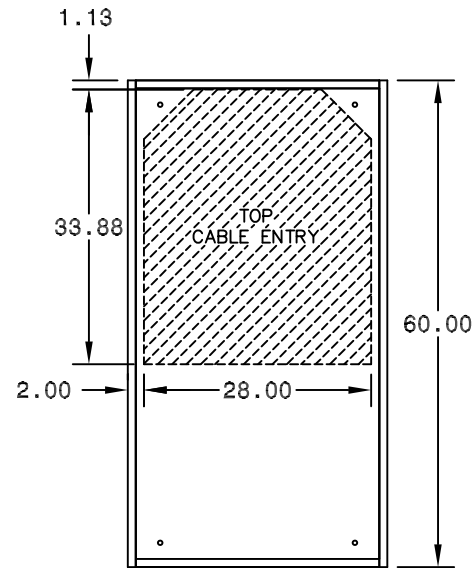

TOP VIEW

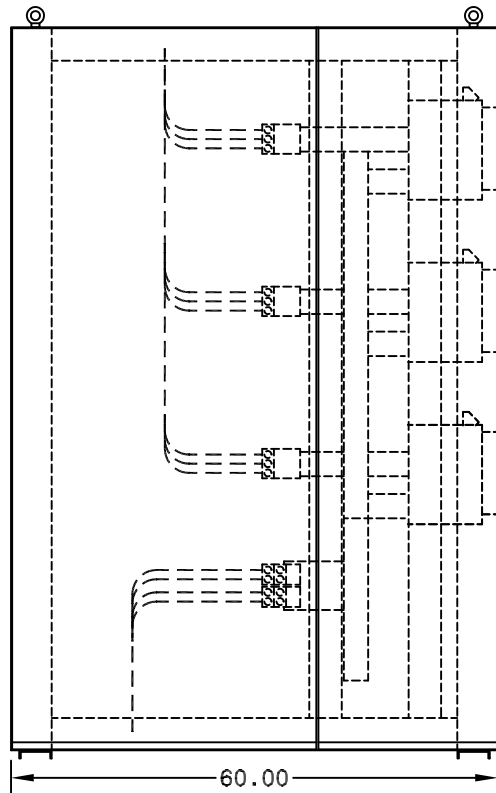

LEFT SIDE VIEW

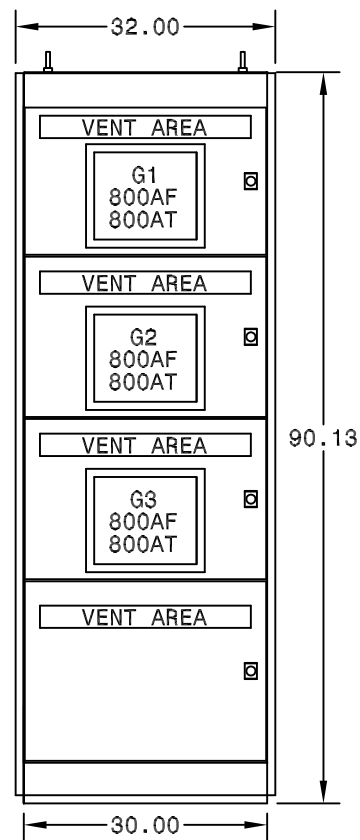

FRONT VIEW

OUTLINE NOTES

- 1) GENERAL ENCLOSURE CONSTRUCTION:
 - A) FREE-STANDING NEMA 1 ENCLOSURE
 - B) 14 GA. DOORS & COVERS
 - C) 11 GA. FRAME
 - D) 1.0"x4.0" 7 GA. CHANNEL BASE
 - E) FRONT & REAR DOORS, PADLOCKABLE
 - F) REMOVABLE, BOLT-ON COVERS (TOP & SIDES)
 - G) OPEN BOTTOM FOR CABLE ENTRY
 - H) FRONT & REAR ACCESS REQUIRED
 - I) PAINTED ANSI-61 LIGHT GRAY
- 2) LUGS:
 - A) 800A CB(S) - (3) #2-600MCM PER PHASE & NE
 - B) 3000A MAIN - (8) 300-800MCM PER PHASE & NE

-	-	-	-	-
-	-	-	-	-
-	-	-	-	-
REV	DESCRIPTION	BY	APV	DATE
 LAKE SHORE ELECTRIC Corp BEDFORD, OHIO U.S.A.				
INDOOR SWITCHBOARD 277/480VAC 3P 4W 3000A OUTLINE				
SCALE: 1=24	DRN: --- --/--/--	CHK: --- --/--/--	APV: --- --/--/--	
<small>THIS DOCUMENT IS THE PROPERTY OF Lake Shore Electric Corporation. UNDER COPYRIGHT LAW, DISTRIBUTION AND REPRODUCTION OF THIS DOCUMENT, IN WHOLE OR IN PART, IS PROHIBITED WITHOUT PRIOR WRITTEN PERMISSION FROM Lake Shore Electric Corporation.</small>				
PROJ: -				
CUSTOMER: -				
			DWG NUMBER	-
			XX2-XXXX-02	-
			QUOTE/JOB#:	PG 1 OF 1